**D Betriebsanleitung**

Turbotrimmer

GB Operating Instructions

Turbotrimmer

F Mode d'emploi

Coupe bordures

NL Instructies voor gebruik

Turbotrimmer

S Bruksanvisning

freeTrim

DK Brugsanvisning

freeTrim

I Istruzioni per l'uso

Turbotrimmer

E Manual de instrucciones

Turbotrimmer

P Instruções de utilização

Turbotrimmer

FIN Käyttöohje

Turbotrimmeri

N Bruksanvisning

Turbotrimmer

GARDENA Turbotrimmer

AccuCut 400 Li / AccuCut 450 Li

Welcome to the Garden of GARDENA...



Translation of the original instructions from German.
Please read these operating instructions carefully and observe the information they contain. Use these operating instructions to familiarise yourself with the GARDENA Turbotrimmer, its proper use and the notes on safety.



For safety reasons, children under the age of 16 as well as people who are not familiar with the operating instructions, should not use the Turbotrimmer. Persons with reduced physical or mental abilities may use the product only if they are supervised or instructed by a responsible person.

→ Please keep these operating instructions in a safe place.

Contents

1. Where to Use Your GARDENA Turbotrimmer	12
2. Safety Instructions	12
3. Assembly	14
4. Initial Operation	15
5. Operation	15
6. Storage	17
7. Maintenance	18
8. Troubleshooting	18
9. Accessories	19
10. Technical Data	20
11. Service / Warranty	20

1. Where to Use Your GARDENA Turbotrimmer

Proper use

The GARDENA Turbotrimmer is designed for trimming and cutting areas of grass and lawns in private house and hobby gardens. The Turbotrimmer must not be used in public facilities, parks, sports grounds, next to roads or in agriculture or forestry.

Please note



For safety reasons, the GARDENA Turbotrimmer must not be used for hedge trimming or for shredding for composting.

2. Safety Instructions

→ Please read the notes on safety on the Trimmer.



CAUTION !
→ Always read the operating instructions before using your Turbotrimmer.



DANGER !
Risk of injury to other people!
→ Keep other people out of the area where you are working.



DANGER !
→ Keep your Turbotrimmer away from water and rain!



DANGER !
Risk of injury to eyes!
→ Always wear eye protection!



DANGER ! Tool does not stop immediately when turned off!

- **Keep your hands and feet out of the area where you are working until the cutting filament is stationary!**

Check your Trimmer before each use

- Always visually inspect your Trimmer before each use.
 - Check that the ventilation slots are not obstructed in any way.
- Do not use Trimmer when safety devices (starting lock-out, start button, safety cover) and/or blade are damaged or worn.
- Never bypass the safety devices.
 - Inspect the area to be cut before you begin work. Remove any foreign objects and look out for foreign objects (such as stones, pieces of wood, strings and wires) while you are working.
 - If you should come across an obstacle while cutting, turn off the Trimmer. Remove the object and check the Trimmer for any damage. If necessary have your Trimmer repaired.

Use / responsibility

The Trimmer can cause serious injuries.

- Use the Trimmer only for the purpose specified in these operating instructions.
- You are responsible for the safety in the area where you are working.
- Ensure that there are no other people (especially children) or animals within or near the area where you are working.
 - Never use the Trimmer if the safety devices are damaged or defective.

After use, regularly check Trimmer – in particular the blade – for damage and repair as appropriate.

- Always wear an eye shield or safety goggles!
- Wear sturdy shoes and long trousers to protect your legs. Keep fingers and feet away from blade – in particular with initial operation!
- Always ensure that you have a secure foothold whilst working.

Take extra care when walking backwards. You may stumble!

- Only work in the daylight or when visibility is good.



DANGER !
Personal injury and damage to property!

- **Keep hands and feet away from blades, especially when Trimmer is switched on!**

The Trimmer should only be used with the blade carrier also supplied and original GARDENA Spare Blades.

Interrupting work

Never leave the Trimmer unattended where you are working.

- If you stop work, store your Trimmer in a safe place.
- If you stop work in order to move to another part of the garden, always switch off the Trimmer and wait until the blade stops.

Familiarise yourself with the surroundings

- Familiarise yourself with the surroundings and look out for possible dangers which you may not hear due to machine noise.
- Never use the Turbotrimmer when it is raining or in damp, wet areas.

Battery safety



FIRE RISK !

- **Never charge the batteries near acids or easily inflammable materials.**

Only use the original GARDENA Battery Charger for charging. The use of other battery chargers may damage the batteries irreparably and even cause a fire.



RISK OF EXPLOSION !

- **Protect Accu Trimmer from heat and fire.**

Do not leave on radiators or expose to strong sunshine for long periods.

Only use your Accu Trimmer in an ambient temperature between -10°C and $+45^{\circ}\text{C}$.

The charging cable should be checked regularly for signs of damage or ageing (brittleness) and may only be used if it is in perfect condition.

The charger unit provided may only be used to charge the rechargeable batteries supplied with the Turbotrimmer.

Non-rechargeable batteries must not be charged with this battery charger (danger of fire).

Only charge battery between 10 – 45 °C. After heavy duty service allow battery to cool down first.

Storage:

The trimmer must not be stored over 35 °C or under direct exposure to sunlight.
Do not store the trimmer in places with static electricity.

3. Assembly

Assembling the trimmer:

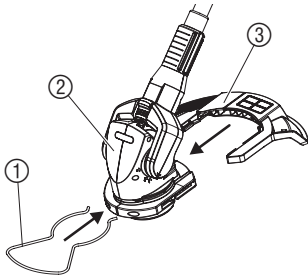

1. Push the cover ③ into the guide of the cutting head from behind ② until the connection locks into place on both sides.
2. Push plant guard ① onto the cutting head from the front ② until it locks into place.

Fit magazine for spare blades:

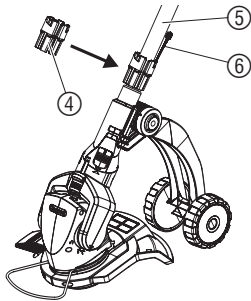

20 plastic blades and a magazine for spare blades are supplied with your trimmer. Up to 6 spare blades can be stored in the magazine.

1. Slightly widen magazine ④ at open point and slide onto handle ⑤.
2. Insert up to 6 plastic blades ⑥ in the magazine ④ until the blades jam.

To fit blade into blade carrier see 8. Troubleshooting "Replacing blades".

Fit additional wheel:

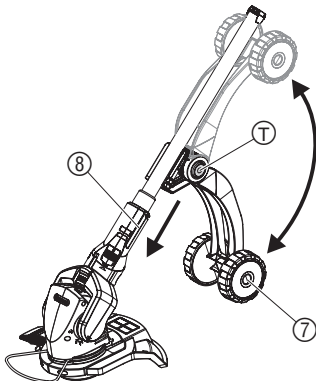

The additional wheel is available as an optional extra for the AccuCut 400 Li. The additional wheel is already fitted on the AccuCut 450 Li.

Fit additional wheel:

→ Fit additional wheel ⑦ onto the guides of the handle holder ⑧ until you hear the connection lock into place on both sides.

Remove additional wheel:

→ Pull both catches ⑨ out to the side and remove the additional wheel ⑦ from the guides of the handle holder ⑧.

Fold additional wheel up / down:

→ Press adjusting buttons T on both sides, fold additional wheel up / down ⑦ and release the adjustment buttons T again.

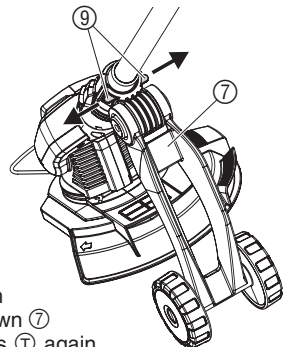

4. Initial Operation

Charging the battery:

Before using for the first time, the battery must be fully charged. Charging time (for uncharged battery) approx. 3 hrs.

The lithium-ion battery can be charged in any state of charge, and the charging process can be interrupted at any time without harming the battery (no memory effect).

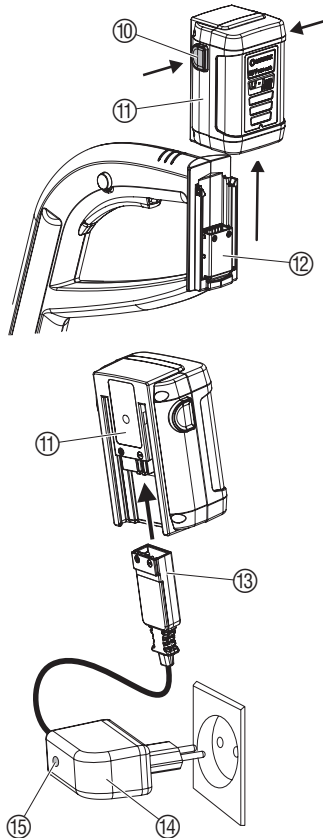

WARNING !
Overvoltage damages batteries and the battery charger.
→ **Ensure the correct mains voltage.**

1. Press the locking buttons in ⑩ and remove the battery ⑪ from the upper part of the handle ⑫.
2. Plug the plug of the charger cable ⑬ into the battery ⑪.
3. Plug battery charger ⑭ into a mains socket.
The charging indicator lamp ⑮ on the battery charger lights up red. The battery is being charged.

When the charging indicator lamp ⑮ lights up green, the battery is fully charged.

4. First remove the charging cable from the charging socket and then unplug the battery charger from the mains socket.
5. Push the battery ⑪ down onto the upper part of the handle ⑫.

Avoid exhaustive discharge:

Do not wait until the blade comes to an absolute stop (battery totally discharged) as this shortens the battery life.

→ If the output of the trimmer decreases noticeably, charge the battery.

If the battery has been totally discharged, the LED will flash at the start of charging. If the LED is still flashing after an hour, a fault has occurred (see 8. Troubleshooting).

5. Operation

RISK OF INJURY !



Risk of injury if the Turbotrimmer does not switch off when you release the start button.

→ **Never bypass the safety devices (by binding the start button to the handle, for example).**

Setting the working position:

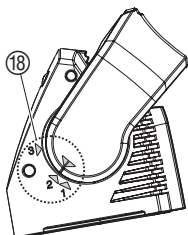
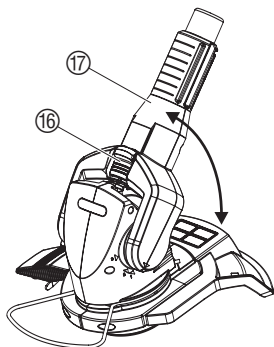

Setting the trimmer to body height:

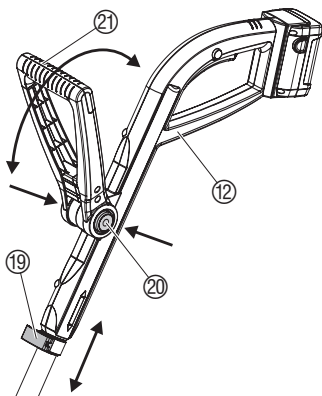

Adjusting the plant guard:



ATTENTION!

Overloading of the motor.

→ When trimming with wheels, working position 2 must be set.



Working position 1:
Trimming without wheels

Working position 2:
Trimming with wheels

Working position 3:
Trimming under obstacles

The angle of the handle can be set to 3 working positions.

1. Push slider 16 up and set the handle 17 to the required working position (see scale 18).
2. Let the slider 16 lock into the required working position.

Setting the handle length:

→ Open clamping lever 19, extend upper part of handle 12 to required handle length and close clamping lever 19 again.

ATTENTION! With AccuCut 400 Li, ensure that when adjusting the handle length the upper part of the handle 12 is not twisted.

Adjusting the additional handle:

→ Press adjusting buttons in 20 on both sides, set additional handle 21 to required angle and release the adjusting buttons 20 again.

When the trimmer is set to the correct body size, the body is upright and the cutting head is angled slightly forwards in working position.

→ Hold the trimmer on the upper part of the handle 12 and additional handle 21 in such a way that the cutting head is angled forwards slightly.

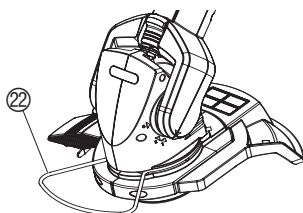

Working position

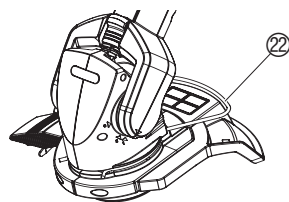

Parking position

→ Turn plant guard 22 through 180° into the required position until it locks into place.

Trimming overhanging lawn edges:



AccuCut 450 Li:

1. Setting the plant guard ⑳ to parking position (see "Adjusting the plant guard").
2. Set handle angle to position 3 (see "Setting the working position").
3. Push slider ㉓ upwards, turn handle ㉔ through 90° and let slider ㉓ lock into place (see arrows ㉐ on articulated fork and handle holder).

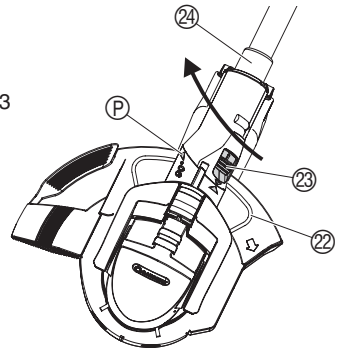

AccuCut 400 Li:

- Open clamping lever ㉑, turn upper part of handle ㉒ through 180° and close clamping lever ㉑ again.

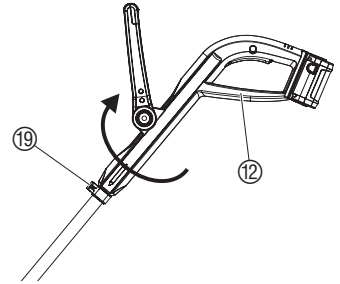

Starting the trimmer:

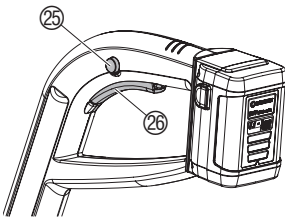

Switching the trimmer on:

1. Press and hold the safety lock ㉕ and then press the start button ㉖ on the handle.
2. Release the safety lock ㉕ again.

Switching the trimmer off:

- Release the start button ㉖ on the handle.

6. Storage

Storage:

The Turbotrimmer must be stored out of the reach of children.

1. Clean Trimmer (see 7. Maintenance).
2. Remove blade from blade carrier for storage (see 8. Troubleshooting).
3. Charging the battery (see 4. Initial Operation).
4. Store the Trimmer in a dry place protected from frost.

Recommendation:

The trimmer can be hung up by the handle. The cutting head is not put under any unnecessary strain if the trimmer is stored hanging up.

Disposal:
(in accordance with
RL2002/96/EC)



The product must not be added to normal household waste. It must be disposed of in line with local environmental regulations.
→ Important: Make sure that the unit is disposed of via your municipal recycling collection centre.

**Disposal of
batteries:**



The GARDENA Accu-Trimmer contains lithium-ion batteries that should not be discarded with normal household waste at the end of their life.

Important:

Please return the lithium-ion batteries to your GARDENA dealer or dispose of them properly at a public recycling centre.

1. Discharge lithium-ion cells completely.
2. Dispose of lithium-ion cells properly.

7. Maintenance

DANGER!
Risk of injury!



Risk of injury from blade!
→ Do not switch Trimmer on for maintenance!

CAUTION!



Risk of injury and risk of damage to property!
→ Never clean the Turbotrimmer under running water or with a water jet (in particular a high pressure water jet).

**Cleaning the cover
and ventilation slots:**

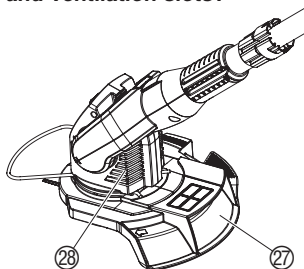

The ventilation slots must always be free of dirt.

→ Remove any grass and dirt from the cover ⑰ and ventilation slots ⑱ after each use.

8. Troubleshooting

DANGER!
Risk of injury!



Risk of injury from blade!
→ Do not switch Trimmer on for troubleshooting!

Replacing blades:



DANGER! Risk of injury!
→ Never use metal cutting elements or spare parts and accessories not intended for use by GARDENA.

Replacing blades:

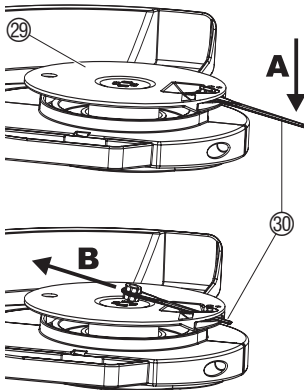

Only use original GARDENA Spare Blades. Spare blades are available from your GARDENA dealer or direct from GARDENA Service.

- GARDENA Spare Blades for Turbotrimmer AccuCut 400 Li / AccuCut 450 Li **Art. No. 5368**

Remove blade:

1. Turn Trimmer round and place on rubber pad of handle.
2. Press end of blade down slightly **(A)**, slide blade **(30)** inside through blade carrier **(29)** **(B)** and pull out.

Fit blade:

- Slide new blade **(30)** from inside through slot in metal of blade carrier **(29)** until it snaps into place.

When the new blade is correctly inserted, it can be moved more easily.

Fault	Possible cause	Remedy
The Trimmer is not cutting cleanly or not cutting at all	Blade worn or too short.	→ Replace blade.
	Blade broken off.	→ Replace blade.
	Battery is flat.	→ Charge battery.
Charging indicator lamp does not light up	Battery charger or charging cable not plugged in properly.	→ Plug in battery charger and charging cable properly.
Charging indicator lamp flashes for more than 1 hour	A fault has occurred. If this does not eliminate the fault, please contact GARDENA Service.	→ Unplug and reinsert charging cable. <i>The fault will be reset.</i>
The battery can no longer be charged	Battery is defective. Only the original GARDENA Replacement Battery 18 V (Art. No. 8839) may be used. This can be obtained from your GARDENA dealer or directly from GARDENA Service.	→ Replace the battery (Art. No. 8839).



In the event of other faults please contact GARDENA Service. Repairs should only be carried out by GARDENA service centres or dealers authorised by GARDENA.

9. Accessories

GARDENA Spare Blades	Art. No. 5368
GARDENA Replacement Battery	Art. No. 8839
GARDENA Additional wheel for AccuCut 400 Li	Art. No. 5310

10. Technical Data

Turbotrimmer	AccuCut 400 Li (Art. 8840)	AccuCut 450 Li (Art. 8841)
Cutting width	230 mm	230 mm
Weight	approx. 2.4 kg	approx. 2.8 kg
Rpm of blade carrier	approx. 9,000 rpm	approx. 9,000 rpm
Work area related emission characteristic value $L_{pA}^{1)}$		85 dB (A)
Noise level $L_{WA}^{2)}$	measured 83 dB (A) guaranteed 84 dB (A)	measured 84 dB (A) guaranteed 86 dB (A)
Hand/arm vibration $a_{vhw}^{1)}$	< 2.5 m/s ²	< 2.5 m/s ²
Battery	lithium ion (18 V)	lithium ion (18 V)
Battery capacity	1.6 Ah	1.6 Ah
Battery charging time	lithium ion 3 hrs	lithium ion 3 hrs
Idling time	approx. 40 mins (with full battery)	approx. 40 mins (with full battery)
Battery charger		
Mains voltage	230 V / 50 Hz	230 V / 50 Hz
Rated output current	600 mA	600 mA
Max. output voltage	21 V (DC)	21 V (DC)

Measuring method according to 1) EN 786 2) directive 2000/14/EC

11. Service / Warranty

GARDENA guarantees this product for 2 years (from date of purchase). This guarantee covers all serious defects of the unit that can be proved to be material or manufacturing faults. Under warranty we will either replace the unit or repair it free of charge if the following conditions apply:

- The unit must have been handled properly and in keeping with the requirements of the operating instructions.
- Neither the purchaser or a non-authorized third party have attempted to repair the unit.

The slide blade and the blade carrier are consumables and are not covered by the guarantee.

This manufacturer's guarantee does not affect the user's existing warranty claims against the dealer/seller.

If a fault occurs with your Turbotrimmer, please return the faulty unit together with a copy of the receipt and a description of the fault, with postage paid to one of the GARDENA Service Centres listed on the back of these operating instructions.

<p>D <i>Produkthftung</i></p>	<p>Wir weisen ausdrücklich darauf hin, dass wir nach dem Produkthaftungsgesetz nicht für durch unsere Geräte hervorgerufene Schäden einzustehen haben, sofern diese durch unsachgemäße Reparatur verursacht oder bei einem Teileaustausch nicht unsere Original GARDENA Teile oder von uns freigegebene Teile verwendet werden und die Reparatur nicht vom GARDENA Service oder dem autorisierten Fachmann durchgeführt wird. Entsprechendes gilt für Ergänzungssteile und Zubehör.</p>
<p>GB <i>Product Liability</i></p>	<p>We expressly point out that, in accordance with the product liability law, we are not liable for any damage caused by our units if it is due to improper repair or if parts exchanged are not original GARDENA parts or parts approved by us, and, if the repairs were not carried out by a GARDENA Service Centre or an authorised specialist. The same applies to spare parts and accessories.</p>
<p>F <i>Responsabilité</i></p>	<p>Nous vous signalons expressément que GARDENA n'est pas responsable des dommages causés par ses appareils, dans la mesure où ces dommages seraient causés suite à une réparation non conforme, dans la mesure où, lors d'un échange de pièces, les pièces d'origine GARDENA n'auraient pas été utilisées, ou si la réparation n'a pas été effectuée par le Service Après-Vente GARDENA ou l'un des Centres SAV agréés GARDENA. Ceci est également valable pour tout ajout de pièces et d'accessoires autres que ceux préconisés par GARDENA.</p>
<p>NL <i>Productaansprakelijkheid</i></p>	<p>Wij wijzen er nadrukkelijk op, dat wij op grond van de wet aansprakelijkheid voor producten niet aansprakelijk zijn voor schade ontstaan door onze apparaten, indien deze door onvakkundige reparatie veroorzaakt zijn, of er bij het uitwisselen van onderdelen geen gebruik gemaakt werd van onze originele GARDENA onderdelen of door ons vrijgegeven onderdelen en de reparatie niet door de GARDENA technische dienst of de bevoegde vakman uitgevoerd werd. Ditzelfde geldt voor extra-onderdelen en accessoires.</p>
<p>S <i>Produktansvar</i></p>	<p>Tillverkaren är inte ansvarig för skada som orsakats av produkten om skadan beror på att produkten har reparerats felaktigt eller om, vid reparation eller utbyte, andra än Original GARDENA reservdelar har använts. Samma sak gäller för kompletteringsdelar och tillbehör.</p>
<p>DK <i>Produktansvar</i></p>	<p>Vi gør udtrykkeligt opmærksom på at i henhold til produktansvarsloven er vi ikke ansvarlige for skader forårsaget af vores udstyr, hvis det skyldes uautoriserede reparationer eller hvis dele er skiftet ud og der ikke er anvendt originale GARDENA dele eller dele godkendt af os, eller hvis reparationerne ikke er udført af GARDENA-service eller en autoriseret fagmand. Det samme gælder for ekstra udstyr og tilbehør.</p>
<p>I <i>Responsabilità del prodotto</i></p>	<p>Si rende espressamente noto che, conformemente alla legislazione sulla responsabilità del prodotto, non si risponde di danni causati da nostri articoli se originati da riparazioni eseguite non correttamente o da sostituzioni di parti effettuate con materiale non originale GARDENA o comunque da noi non approvato e, in ogni caso, qualora l'intervento non venga eseguito da un centro assistenza GARDENA o da personale specializzato autorizzato. Lo stesso vale per le parti complementari e gli accessori.</p>
<p>E <i>Responsabilidad de productos</i></p>	<p>Advertimos que conforme a la ley de responsabilidad de productos no nos responsabilizamos de daños causados por nuestros aparatos, siempre y cuando dichos daños hayan sido originados por arreglos o reparaciones indebidas, por recambios con piezas que no sean piezas originales GARDENA o bien piezas autorizadas por nosotros, así como en aquellos casos en que la reparación no haya sido efectuada por un Servicio Técnico GARDENA o por un técnico autorizado. Lo mismo es aplicable para las piezas complementarias y accesorios.</p>
<p>P <i>Responsabilidade sobre o produto</i></p>	<p>Queremos salientar que segundo a lei da responsabilidade do fabricante, nós não nos responsabilizaremos por danos causados pelo nosso equipamento, quando estes ocorram em decorrência de reparações inadequadas ou da substituição de peças por peças não originais da GARDENA, ou peças não autorizadas. A responsabilidade tornar-se-à nula também depois de reparações realizadas por oficinas não autorizadas pela GARDENA. Esta restrição valerá também para peças adicionais e acessórios.</p>

FIN Tuotevastuu	Korostamme nimenomaan, että tuotevastuulain nojalla emme ole vastuussa laitteistamme johtuneista vahingoista, mikäli nämä ovat aiheutuneet epäasianmukaisesta korjauksesta tai osia vaihdettaessa ei ole käytetty alkuperäisiä GARDENA- varaosia tai hyväksymiämme osia ja korjauksen on suorittanut muu kuin GARDENA -huoltokeskus tai valtuuttamamme ammattihenkilö. Tämä pätee myös lisäosiin ja lisävarusteisiin.
N Produktansvar	Vi gjør uttrykkelig oppmerksom på at vi i henhold til produktansvarsloven ikke er ansvarlige for skader forårsaket av redskapet vårt hvis dette skyldes usakkyndige reparasjoner eller hvis deler er skiftet ut og det ikke ble benyttet våre originale GARDENA deler eller deler som er godkjent av oss og reparasjonen ikke er utført av GARDENA service eller den autoriserte fagmannen. Det samme gjelder for supplerende deler og tilbehør.

D EU-Konformitätserklärung Maschinenverordnung (9. GSGVO) / EMVG / Niedersp. RL Der Unterzeichnete GARDENA Manufacturing GmbH, Hans-Lorenser-Str. 40, D-89079 Ulm, bestätigt, dass die nachfolgend bezeichneten Geräte in der von uns in Verkehr gebrachten Ausführung die Anforderungen der harmonisierten EU-Richtlinien, EU-Sicherheitsstandards und produktspezifischen Standards erfüllen. Bei einer nicht mit uns abgestimmten Änderung der Geräte verliert diese Erklärung ihre Gültigkeit.	<table border="0"> <tr> <td>Bezeichnung des Gerätes:</td> <td>Turbotrimmer</td> </tr> <tr> <td>Description of the unit:</td> <td>Turbotrimmer</td> </tr> <tr> <td>Désignation du matériel :</td> <td>Coupe bordures</td> </tr> <tr> <td>Omschrijving van het apparaat:</td> <td>Turbotrimmer</td> </tr> <tr> <td>Produktbeschreibung:</td> <td>Turbotrimmer</td> </tr> <tr> <td>Beskrivelse af enhederne:</td> <td>Turbotrimmer</td> </tr> <tr> <td>Descrizione del prodotto:</td> <td>Turbotrimmer</td> </tr> <tr> <td>Descripción de la mercancía:</td> <td>Turbotrimmer</td> </tr> <tr> <td>Descrição do aparelho:</td> <td>Turbotrimmer</td> </tr> <tr> <td>Laitteiden nimitys:</td> <td>Turbotrimmeri</td> </tr> <tr> <td>Betegnelse for redskapet:</td> <td>Turbotrimmer</td> </tr> </table>	Bezeichnung des Gerätes:	Turbotrimmer	Description of the unit:	Turbotrimmer	Désignation du matériel :	Coupe bordures	Omschrijving van het apparaat:	Turbotrimmer	Produktbeschreibung:	Turbotrimmer	Beskrivelse af enhederne:	Turbotrimmer	Descrizione del prodotto:	Turbotrimmer	Descripción de la mercancía:	Turbotrimmer	Descrição do aparelho:	Turbotrimmer	Laitteiden nimitys:	Turbotrimmeri	Betegnelse for redskapet:	Turbotrimmer																										
Bezeichnung des Gerätes:	Turbotrimmer																																																
Description of the unit:	Turbotrimmer																																																
Désignation du matériel :	Coupe bordures																																																
Omschrijving van het apparaat:	Turbotrimmer																																																
Produktbeschreibung:	Turbotrimmer																																																
Beskrivelse af enhederne:	Turbotrimmer																																																
Descrizione del prodotto:	Turbotrimmer																																																
Descripción de la mercancía:	Turbotrimmer																																																
Descrição do aparelho:	Turbotrimmer																																																
Laitteiden nimitys:	Turbotrimmeri																																																
Betegnelse for redskapet:	Turbotrimmer																																																
GB EU Certificate of Conformity The undersigned GARDENA Manufacturing GmbH, Hans-Lorenser-Str. 40, D-89079 Ulm, hereby certifies that, when leaving our factory, the units indicated below are in accordance with the harmonised EU guidelines, EU standards of safety and product specific standards. This certificate becomes void if the units are modified without our approval.	<table border="0"> <tr> <td>Typ:</td> <td></td> <td>Art.-Nr.:</td> <td></td> </tr> <tr> <td>Type:</td> <td></td> <td>Art. No.:</td> <td></td> </tr> <tr> <td>Type :</td> <td></td> <td>Référence :</td> <td></td> </tr> <tr> <td>Type:</td> <td></td> <td>Art. nr.:</td> <td></td> </tr> <tr> <td>Typ:</td> <td>AccuCut 400 Li</td> <td>Art.nnr.:</td> <td>8840</td> </tr> <tr> <td>Type:</td> <td></td> <td>Varenr.:</td> <td></td> </tr> <tr> <td>Modello:</td> <td>AccuCut 450 Li</td> <td>Art.:</td> <td>8841</td> </tr> <tr> <td>Tipo:</td> <td></td> <td>Art. Nº:</td> <td></td> </tr> <tr> <td>Tipo:</td> <td></td> <td>Art. Nº:</td> <td></td> </tr> <tr> <td>Tyyppi:</td> <td></td> <td>Art.-n:o.:</td> <td></td> </tr> <tr> <td>Typert:</td> <td></td> <td>Art.-Nr.:</td> <td></td> </tr> </table>	Typ:		Art.-Nr.:		Type:		Art. No.:		Type :		Référence :		Type:		Art. nr.:		Typ:	AccuCut 400 Li	Art.nnr.:	8840	Type:		Varenr.:		Modello:	AccuCut 450 Li	Art.:	8841	Tipo:		Art. Nº:		Tipo:		Art. Nº:		Tyyppi:		Art.-n:o.:		Typert:		Art.-Nr.:					
Typ:		Art.-Nr.:																																															
Type:		Art. No.:																																															
Type :		Référence :																																															
Type:		Art. nr.:																																															
Typ:	AccuCut 400 Li	Art.nnr.:	8840																																														
Type:		Varenr.:																																															
Modello:	AccuCut 450 Li	Art.:	8841																																														
Tipo:		Art. Nº:																																															
Tipo:		Art. Nº:																																															
Tyyppi:		Art.-n:o.:																																															
Typert:		Art.-Nr.:																																															
F Certificat de conformité aux directives européennes Le constructeur, soussigné : GARDENA Manufacturing GmbH, Hans-Lorenser-Str. 40, D-89079 Ulm, déclare qu'à la sortie de ses usines le matériel neuf désigné ci-dessous était conforme aux prescriptions des directives européennes énoncées ci-après et conforme aux règles de sécurité et autres règles qui lui sont applicables dans le cadre de l'Union européenne. Toute modification portée sur ce produit sans l'accord express de GARDENA supprime la validité de ce certificat.	<table border="0"> <tr> <td>EU-Richtlinien:</td> <td></td> <td>Harmonisierte EN:</td> <td></td> </tr> <tr> <td>EU directives:</td> <td></td> <td></td> <td></td> </tr> <tr> <td>Directives</td> <td>98/37/EC : 1998</td> <td>EN ISO 12100-1</td> <td></td> </tr> <tr> <td>européennes :</td> <td>2006/42/EC : 2006</td> <td>EN ISO 12100-2</td> <td></td> </tr> <tr> <td>EU-richtlijnen:</td> <td></td> <td></td> <td></td> </tr> <tr> <td>EU direktiv:</td> <td>2006/95/EC</td> <td>EN 786</td> <td></td> </tr> <tr> <td>EU Retningslinier:</td> <td>2004/108/EC</td> <td>EN 60335-1</td> <td></td> </tr> <tr> <td>Direttive UE:</td> <td>93/68/EC</td> <td>EN 60335-2-91</td> <td></td> </tr> <tr> <td>Normativa UE:</td> <td></td> <td>ISO 4871</td> <td></td> </tr> <tr> <td>Directrices da UE:</td> <td>2000/14/EC</td> <td></td> <td></td> </tr> <tr> <td>EY-direktiivit:</td> <td></td> <td></td> <td></td> </tr> <tr> <td>EU-direktiver:</td> <td></td> <td></td> <td></td> </tr> </table>	EU-Richtlinien:		Harmonisierte EN:		EU directives:				Directives	98/37/EC : 1998	EN ISO 12100-1		européennes :	2006/42/EC : 2006	EN ISO 12100-2		EU-richtlijnen:				EU direktiv:	2006/95/EC	EN 786		EU Retningslinier:	2004/108/EC	EN 60335-1		Direttive UE:	93/68/EC	EN 60335-2-91		Normativa UE:		ISO 4871		Directrices da UE:	2000/14/EC			EY-direktiivit:				EU-direktiver:			
EU-Richtlinien:		Harmonisierte EN:																																															
EU directives:																																																	
Directives	98/37/EC : 1998	EN ISO 12100-1																																															
européennes :	2006/42/EC : 2006	EN ISO 12100-2																																															
EU-richtlijnen:																																																	
EU direktiv:	2006/95/EC	EN 786																																															
EU Retningslinier:	2004/108/EC	EN 60335-1																																															
Direttive UE:	93/68/EC	EN 60335-2-91																																															
Normativa UE:		ISO 4871																																															
Directrices da UE:	2000/14/EC																																																
EY-direktiivit:																																																	
EU-direktiver:																																																	
NL EU-overeenstemmingsverklaring Ondergetekende GARDENA Manufacturing GmbH, Hans-Lorenser-Str. 40, D-89079 Ulm, bevestigt, dat het volgende genoemde apparaat in de door ons in de handel gebrachte uitvoering voldoet aan de eis van, en in overeenstemming is met de EU-richtlijnen, de EU-veiligheidsstandaard en de voor het product specifieke standaard. Bij een niet met ons afgestemde verandering aan het apparaat verliest deze verklaring haar geldigheid.	<table border="0"> <tr> <td>Hinterlegte Dokumentation:</td> <td>GARDENA Technische Dokumentation</td> </tr> <tr> <td>Konformitätsbewertungsverfahren:</td> <td>Nach 2000/14/EG Art. 14 Anhang VI</td> </tr> <tr> <td>Deposited Documentation:</td> <td>GARDENA Technical Documentation</td> </tr> <tr> <td>Conformity Assessment</td> <td>according to 2000/14/EC</td> </tr> <tr> <td>Procedure:</td> <td>Art. 14 Annex VI</td> </tr> <tr> <td>Documentation déposée :</td> <td>Documentation technique GARDENA</td> </tr> <tr> <td>Procédure d'évaluation de la conformité :</td> <td>Selon 2000/14/CE art. 14 Annexe VI</td> </tr> </table>	Hinterlegte Dokumentation:	GARDENA Technische Dokumentation	Konformitätsbewertungsverfahren:	Nach 2000/14/EG Art. 14 Anhang VI	Deposited Documentation:	GARDENA Technical Documentation	Conformity Assessment	according to 2000/14/EC	Procedure:	Art. 14 Annex VI	Documentation déposée :	Documentation technique GARDENA	Procédure d'évaluation de la conformité :	Selon 2000/14/CE art. 14 Annexe VI																																		
Hinterlegte Dokumentation:	GARDENA Technische Dokumentation																																																
Konformitätsbewertungsverfahren:	Nach 2000/14/EG Art. 14 Anhang VI																																																
Deposited Documentation:	GARDENA Technical Documentation																																																
Conformity Assessment	according to 2000/14/EC																																																
Procedure:	Art. 14 Annex VI																																																
Documentation déposée :	Documentation technique GARDENA																																																
Procédure d'évaluation de la conformité :	Selon 2000/14/CE art. 14 Annexe VI																																																
S EU Tillverkarintyg Undertecknad firma GARDENA Manufacturing GmbH, Hans-Lorenser-Str. 40, D-89079 Ulm, intygar härmed att nedan nämnda produkter överensstämmer med EU:s direktiv, EU:s säkerhetsstandard och produktspecifikation. Detta intyg upphör att gälla om produkten ändras utan vårt tillstånd.	<table border="0"> <tr> <td>Schall-Leistungspegel:</td> <td>gemessen / garantiert</td> </tr> <tr> <td>Noise level:</td> <td>measured / guaranteed</td> </tr> <tr> <td>Puissance acoustique :</td> <td>mesurée / garantie</td> </tr> <tr> <td>Geluidsniveau:</td> <td>gemeten / gegarandeerd</td> </tr> <tr> <td>Ljudnivå:</td> <td>uppmätt / garanterad</td> </tr> <tr> <td>Lydtryksniveau:</td> <td>atmält / garanti</td> </tr> <tr> <td>Livello rumorosità:</td> <td>testato / garantito</td> </tr> <tr> <td>Nivel sonoro:</td> <td>medido / garantizado</td> </tr> <tr> <td>Nivel de ruido:</td> <td>medido / garantido</td> </tr> <tr> <td>Melun tehostas:</td> <td>mitattu / taattu</td> </tr> <tr> <td>Lydeffektivität:</td> <td>mält / garantert</td> </tr> <tr> <td>AccuCut 400 Li</td> <td>83 dB (A) / 84 dB (A)</td> </tr> <tr> <td>AccuCut 450 Li</td> <td>84 dB (A) / 86 dB (A)</td> </tr> </table>	Schall-Leistungspegel:	gemessen / garantiert	Noise level:	measured / guaranteed	Puissance acoustique :	mesurée / garantie	Geluidsniveau:	gemeten / gegarandeerd	Ljudnivå:	uppmätt / garanterad	Lydtryksniveau:	atmält / garanti	Livello rumorosità:	testato / garantito	Nivel sonoro:	medido / garantizado	Nivel de ruido:	medido / garantido	Melun tehostas:	mitattu / taattu	Lydeffektivität:	mält / garantert	AccuCut 400 Li	83 dB (A) / 84 dB (A)	AccuCut 450 Li	84 dB (A) / 86 dB (A)																						
Schall-Leistungspegel:	gemessen / garantiert																																																
Noise level:	measured / guaranteed																																																
Puissance acoustique :	mesurée / garantie																																																
Geluidsniveau:	gemeten / gegarandeerd																																																
Ljudnivå:	uppmätt / garanterad																																																
Lydtryksniveau:	atmält / garanti																																																
Livello rumorosità:	testato / garantito																																																
Nivel sonoro:	medido / garantizado																																																
Nivel de ruido:	medido / garantido																																																
Melun tehostas:	mitattu / taattu																																																
Lydeffektivität:	mält / garantert																																																
AccuCut 400 Li	83 dB (A) / 84 dB (A)																																																
AccuCut 450 Li	84 dB (A) / 86 dB (A)																																																
DK EU Overensstemmelse certificat Under tegnede GARDENA Manufacturing GmbH, Hans-Lorenser-Str. 40, D-89079 Ulm bekræfter hermed, at enheder listet herunder, ved afsendelse fra fabrikken, er i overensstemmelse med harmoniserede EU retningslinier, EU sikkerhedsstandarder og produktspecifikationsstandarder. Dette certifikat træder ud af kraft hvis enhederne er ændret uden vor godkendelse.	<table border="0"> <tr> <td>Schall-Leistungspegel:</td> <td>gemessen / garantiert</td> </tr> <tr> <td>Noise level:</td> <td>measured / guaranteed</td> </tr> <tr> <td>Puissance acoustique :</td> <td>mesurée / garantie</td> </tr> <tr> <td>Geluidsniveau:</td> <td>gemeten / gegarandeerd</td> </tr> <tr> <td>Ljudnivå:</td> <td>uppmätt / garanterad</td> </tr> <tr> <td>Lydtryksniveau:</td> <td>atmält / garanti</td> </tr> <tr> <td>Livello rumorosità:</td> <td>testato / garantito</td> </tr> <tr> <td>Nivel sonoro:</td> <td>medido / garantizado</td> </tr> <tr> <td>Nivel de ruido:</td> <td>medido / garantido</td> </tr> <tr> <td>Melun tehostas:</td> <td>mitattu / taattu</td> </tr> <tr> <td>Lydeffektivität:</td> <td>mält / garantert</td> </tr> <tr> <td>AccuCut 400 Li</td> <td>83 dB (A) / 84 dB (A)</td> </tr> <tr> <td>AccuCut 450 Li</td> <td>84 dB (A) / 86 dB (A)</td> </tr> </table>	Schall-Leistungspegel:	gemessen / garantiert	Noise level:	measured / guaranteed	Puissance acoustique :	mesurée / garantie	Geluidsniveau:	gemeten / gegarandeerd	Ljudnivå:	uppmätt / garanterad	Lydtryksniveau:	atmält / garanti	Livello rumorosità:	testato / garantito	Nivel sonoro:	medido / garantizado	Nivel de ruido:	medido / garantido	Melun tehostas:	mitattu / taattu	Lydeffektivität:	mält / garantert	AccuCut 400 Li	83 dB (A) / 84 dB (A)	AccuCut 450 Li	84 dB (A) / 86 dB (A)																						
Schall-Leistungspegel:	gemessen / garantiert																																																
Noise level:	measured / guaranteed																																																
Puissance acoustique :	mesurée / garantie																																																
Geluidsniveau:	gemeten / gegarandeerd																																																
Ljudnivå:	uppmätt / garanterad																																																
Lydtryksniveau:	atmält / garanti																																																
Livello rumorosità:	testato / garantito																																																
Nivel sonoro:	medido / garantizado																																																
Nivel de ruido:	medido / garantido																																																
Melun tehostas:	mitattu / taattu																																																
Lydeffektivität:	mält / garantert																																																
AccuCut 400 Li	83 dB (A) / 84 dB (A)																																																
AccuCut 450 Li	84 dB (A) / 86 dB (A)																																																
I Dichiarazione di conformità alle norme UE La sottoscritta GARDENA Manufacturing GmbH, Hans-Lorenser-Str. 40, D-89079 Ulm, certifica che il prodotto qui di seguito indicato, nei modelli da noi commercializzati, è conforme alle direttive armonizzate UE nonché agli standard di sicurezza e agli standard specifici di prodotto. Qualunque modifica apportata al prodotto senza nostra specifica autorizzazione invalida la presente dichiarazione.																																																	

<p>I Dichiarazione di conformità alle norme UE</p> <p>La sottoscritta GARDENA Manufacturing GmbH, Hans-Lorenser-Str. 40, D-89079 Ulm, certifica che il prodotto qui di seguito indicato, nei modelli da noi commercializzati, è conforme alle direttive armonizzate UE nonché agli standard di sicurezza e agli standard specifici di prodotto. Qualunque modifica apportata al prodotto senza nostra specifica autorizzazione invalida la presente dichiarazione.</p>	<p>Anbringningsjahr der CE-Kennzeichnung: Year of CE marking: Date d'apposition du marquage CE : Installatiejaar van de CE-aanduiding: CE-Märkningsår: CE-Mærkningsår: Anno di rilascio della certificazione CE: Colocación del distintivo CE: Ano de marcação pela CE: CE-merkin kiinnitysvuosi: CE-merkingen plassert i:</p> <p style="text-align: right;">2008</p>
<p>E Declaración de conformidad de la UE</p> <p>El que suscribe GARDENA Manufacturing GmbH, Hans-Lorenser-Str. 40, D-89079 Ulm, declara que la presente mercancía, objeto de la presente declaración, cumple con todas las normas de la UE, en lo que a normas técnicas, de homologación y de seguridad se refiere. En caso de realizar cualquier modificación en la presente mercancía sin nuestra previa autorización, esta declaración pierde su validez.</p>	<p>Ulm, den 01.07.2008 Ulm, 01.07.2008 Fait à Ulm, le 01.07.2008 Ulm, 01-07-2008 Ulm, 2008.01.07. Ulm, 01.07.2008 Ulm, 01.07.2008 Ulm, 01.07.2008 Ulm, 01.07.2008 Ulm, 01.07.2008 Ulm, 01.07.2008 Ulm, 01.07.2008</p>
<p>P Certificado de conformidade da UE</p> <p>Os abaixo mencionados GARDENA Manufacturing GmbH, Hans-Lorenser-Str. 40, D-89079 Ulm, por este meio certificam que ao sair da fábrica o aparelho abaixo mencionado está de acordo com as directrizes harmonizadas da UE, padrões de segurança e de produtos específicos. Este certificado ficará nulo se a unidade for modificada sem a nossa aprovação.</p>	<p>Der Bevollmächtigte Authorised representative Représentant légal Gemachtigde Behörig Firmatecknare Teknisk direktør Rappresentante autorizzato Representante autorizado Representante autorizado Valtuutettu edustaja Den fullmektige</p>
<p>FIN EY-vaatimustenmukaisuusvakuutus</p> <p>Allekirjoittanut GARDENA International GmbH, Hans-Lorenser-Straße 40, D-89079 Ulm vakuuttaa, että allamainitut laitteet täyttävät tehtaatamme läh-tiessään yhdenmukaistettujen EY-direktiivien, EY-turvallisuusstandardien ja tuotekohtaisten standardien vaatimukset. Laitteisiin tehdyt muutokset, joista ei ole sovittu kanssamme, johtavat tämän vakuutuksen raukeamiseen.</p>	<p style="text-align: right;"> Peter Lameli Vice President</p>
<p>N EU-samsvarserklæring</p> <p>Den undertegnede GARDENA International GmbH, Hans-Lorenser-Straße 40, D-89079 Ulm erklærer ved dette, at redskapet oppført nedenfor i utførelsen som vi har introdusert på markedet er i samsvar med kravene i de harmoniserte EU-direktivene, EU-sikkerhetsstandarder og produktspesifikke standarder. Ved en endring av redskapet som ikke er avstemt med oss, taper denne erklæringen sin gyldighet.</p>	

Deutschland / Germany

GARDENA
Manufacturing GmbH
Central Service
Hans-Lorenser-Straße 40
D-89079 Ulm
Produktfragen:
(+49) 731 490-123
Reparaturen:
(+49) 731 490-290
service@gardena.com

Argentina

Husqvarna Argentina S.A.
Vera 745
(C1414AOO) Buenos Aires
Phone: (+54) 11 4858-5000
diego.poggi@ar.husqvarna.com

Australia

Husqvarna Australia Pty. Ltd.
Locked Bag 18
Gosford NSW 2250
Phone: (+61) 0 2 4372 1500
customer.service@
husqvarna.com.au

Austria / Österreich

Husqvarna Austria GmbH
Consumer Products
Industriezeile 36
4010 Linz
Tel.: (+43) 732 77 01 01-90
consumer.service@
husqvarna.at

Belgium

GARDENA Belgium NV/SA
Sterrebeekstraat 163
1930 Zaventem
Phone: (+32) 2 720 92 12
Mail: info@gardena.be

Brazil

Palash Comércio e
Importação Ltda.
Rua São João do Araguaia, 338
- Jardim Califórnia -
Barueri - SP - Brasil -
CEP 06409-060
Phone: (+55) 11 4198-9777
eduardo@palash.com.br

Bulgaria

Хускварна България ЕООД
1799 София
Бул. „Андрей Ляпчев“ № 72
Тел.: (+359) 2 80 99 424
www.husqvarna.bg

Canada

GARDENA Canada Ltd.
100 Summerlea Road
Brampton, Ontario L6T 4X3
Phone: (+1) 905 792 93 30
info@gardenacanada.com

Chile

Antonio Martinic y Cia Ltda.
Cassillas 272
Centro de Cassillas
Santiago de Chile
Phone: (+56) 2 20 10 708
garfar_cl@yahoo.com

Costa Rica

Compania Exim
Euroiberoamericana S.A.
Los Colegios, Moravia,
200 metros al Sur del Colegio
Saint Francis - San José
Phone: (+506) 297 68 83
exim_euro@racsa.co.cr

Croatia

KLIS d.o.o.
Stanceva 79
10419 Vukovina
Phone: (+385) 1 622 777 0
gardena@klis-trgovina.hr

Cyprus

FARMOKIPIKI LTD
P.O. Box 7098
74, Digeni Akritas Ave.
1641 Nicosia
Phone: (+357) 22 75 47 62
condam@spidernet.com.cy

Czech Republic

GARDENA spol. s r.o.
Tuřanka 115
627 00 Brno
Phone: (+420) 548 217 777
gardena@gardenabrn.cz

Denmark

GARDENA
Husqvarna Consumer Outdoor
Products
Salgsafdelning Danmark
Box 9003
S-200 39 Malmö
info@gardena.dk

Estonia

Husqvarna Eesti OÜ
Consumer Outdoor Products
Kesk tee 10, Aaviku küla
Rae vald, Harju maakond
75305
kontakt.etj@husqvarna.ee

Finland

Oy Husqvarna Ab
Consumer Outdoor Products
Lautatarhankatu 8 B / PL 3
00581 HELSINKI
info@gardena.fi

France

GARDENA France
Immeuble Exposial
9-11 allée des Pierres Mayettes
ZAC des Barbanniers, B.P. 99
-F- 92232 GENNEVILLIERS
cedex
Tél. (+33) 01 40 85 30 40
service.consommateurs@
gardena.fr

Great Britain

Husqvarna UK Ltd
Preston Road
Aycliffe Industrial Park
Newton Aycliffe
County Durham
DL5 6UP
info.gardena@
husqvarna.co.uk

Greece

HUSQVARNA GREECE S.A.
Branch of Koropi
Ifestou 33A
Industrial Area Koropi
194 00 Athens - Greece
V.A.T. EL094094640
Phone: (+30) 210 66 20 225
info@husqvarna-consumer.gr

Hungary

Husqvarna
Magyarország Kft.
Ezred u. 1-3
1044 Budapest
Phone: (+36) 80 20 40 33
gardena@gardena.hu

Iceland

Ó. Johnson & Kaaber
Tunguhalsi 1
110 Reykjavik
ooj@ojk.is

Ireland

Michael McLoughlin & Sons
Hardware Limited
Long Mile Road
Dublin 12

Italy

GARDENA Italia S.p.A.
Via Donizetti 22
20020 Lainate (Mi)
Phone: (+39) 02.93.94.79.1
info@gardenaitalia.it

Japan

KAKUICHI Co. Ltd.
Sumitomo Realty &
Development Kojimachi
BLDG. 8F, 5-1 Nibanbany,
Chiyoda-ku, Tokyo 102-0084
Phone: (+81) 33 264 4721
m_ishihara@kaku-ichi.co.jp

Latvia

SIA „Husqvarna Latvija“
Consumer Outdoor Products
Bākūžu iela 6, Rīga, LV-1024
info@husqvarna.lv

Lithuania

UAB Husqvarna Lietuva
Consumer Outdoor Products
Ateities pl. 77C
LT-52104 Kaunas
centras@husqvarna.lt

Luxembourg

Magasins Jules Neuberg
39, rue Jacques Stas
Luxembourg-Gasperich 2549
Case Postale No. 12
Luxembourg 2010
Phone: (+352) 40 14 01
api@neuberg.lu

Netherlands

GARDENA Nederland B.V.
Postbus 50176
1305 AD ALMERE
Phone: (+31) 36 521 00 00
info@gardena.nl

Neth. Antilles

Jonka Enterprises N.V.
Sta. Rosa Weg 196
P.O. Box 8200, Curaçao
Phone: (+599) 9 767 66 55
pgm@jonka.com

New Zealand

Husqvarna New Zealand Ltd.
PO Box 76437
Manukau City 2241
Phone: (+64) 09 9 20 24 10

Norway

GARDENA
Husqvarna Consumer Outdoor
Products
Salgskontor Norge
Kleiveveien 6
1540 Vestby
info@gardena.no

Poland

Husqvarna Poland Spółka z o.o.
Oddział w Szymanowie
Szymanów 9 d
05-532 Baniocha
Phone: (+48) 22 727 56 90
gardena@gardena.pl

Portugal

GARDENA Portugal Lda.
Sintra Business Park
Edifício 1, Fração 0-G
2710-089 Sintra
Phone: (+351) 21 922 85 30
info@gardena.pt

Romania

MADEX INTERNATIONAL SRL
Soseaua Odaii 117-123,
Sector 1,
București, RO 013603
Phone: (+40) 21 352 76 03
madox@ines.ro

Russia

ООО ГАРДЕНА РУС
123007, г. Москва
Хорошевское шоссе, д. 32А
Тел.: (+7) 495 380 31 92
info@gardena-rus.ru

Singapore

Hy-Ray PRIVATE LIMITED
40 Jalan Pemimpin
02-08 Tat Ann Building
Singapore 577185
Phone: (+65) 6253 2277
shiyang@hyray.com.sg

Slovak Republic

GARDENA spol. s r.o.
Tuřanka 115
627 00 Brno
Phone: (+420) 548 217 777
gardena@gardenabrn.cz

Slovenia

GARDENA d.o.o.
Brodskič 15
1236 Trzin
Phone: (+386) 1 580 93 32
servis@gardena.si

South Africa

GARDENA
South Africa (Pty.) Ltd.
P.O. Box 11534
Vorna Valley 1686
Phone: (+27) 11 315 02 23
sales@gardena.co.za

Spain

GARDENA IBÉRICA S.L.U.
C/ Basauri, nº 6
La Florida
28023 Madrid
Phone: (+34) 91 708 05 00
atencioncliente@gardena.es

Sweden

GARDENA
Husqvarna Consumer Outdoor
Products
Försäljningskontor Sverige
Box 9003
200 39 Malmö
info@gardena.se

Switzerland / Schweiz

GARDENA Schweiz AG
Consumer Products
Industriestrasse 10
5506 Mägenwil
Phone: (+41) (0) 848 800 464
info@gardena.ch

Turkey

GARDENA / Dost Diş Ticaret
Müessesilik A.Ş. Sanayi
Çad. Adil Sokak No. 1
Kartal - Istanbul
Phone: (+90) 216 38 93 939
info@gardena-dost.com.tr

Ukraine / Україна

ТОВ «ГАРДЕНА УКРАЇНА»
Васильківська, 34, 204-Г
03022, Київ
Тел. (+38 044) 498 39 02
info@gardena.ua

8840-20.960.03/0109
© GARDENA
Manufacturing GmbH
D-89070 Ulm
http://www.gardena.com